

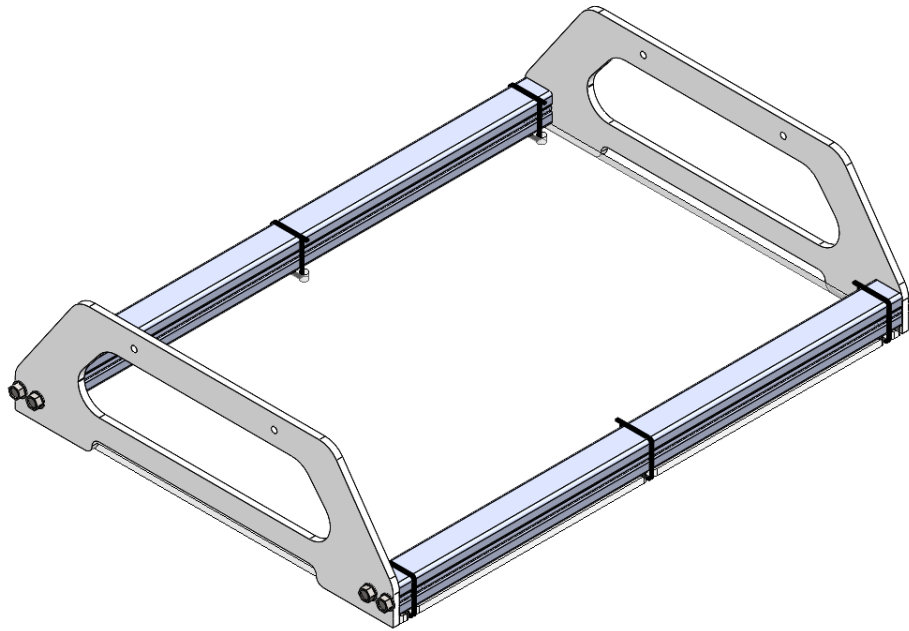





FTC Driver Tray Assembly Directions



Recommended Tool List

Component	Used On	Product Number	Product Photo
3/8 in. Nut Driver	1/4-20 Thread Forming Screws	am-3877	

FTC Driver Tray (am-4845) Parts List

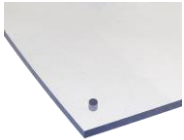
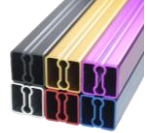
Component	Product Number	Qty	Product Photo
1/4-20 x 1 in. Thread Forming Screw Hex Washer Head	am-1182	8	
8 in. Cable Ties	am-1189_1	6	
Driver Station Tray Handle	am-4616_handle	2	
Driver Tray Bottom Panel	am-4548_panel	1	
1x1 Peanut Extrusion 18 in. Long	am-3090-18_color	2	

Driver Tray Assembly

Step 1: Insert four 1/4-20 Thread Forming Screw (am-1182) through one Driver Tray Handle (am-4616_handle) and loosely secure them through the two Peanut (am-3090-18) sections.

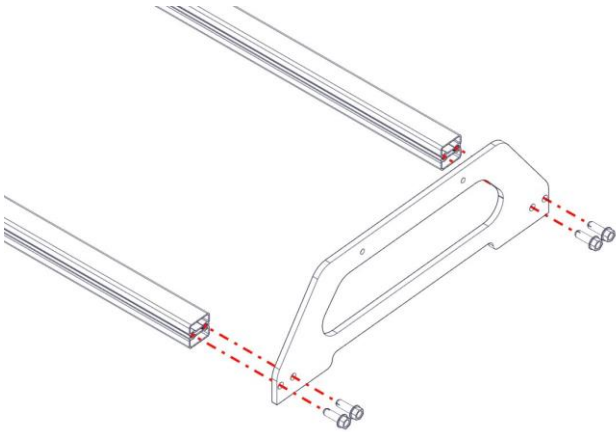

Step 3: Ensure there is a slight gap between the handles and the peanut on both sides.

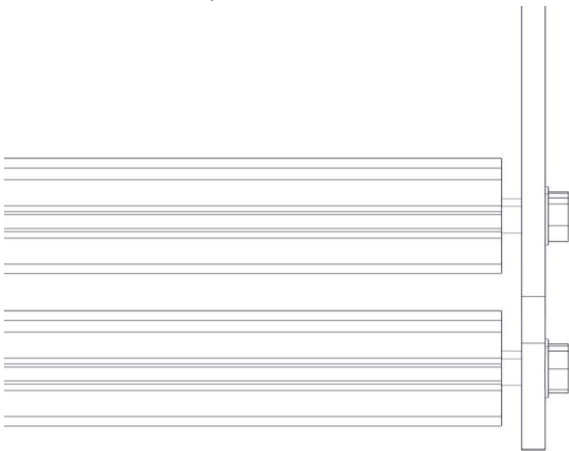

Step 5: Finish securing the handles to the peanut.

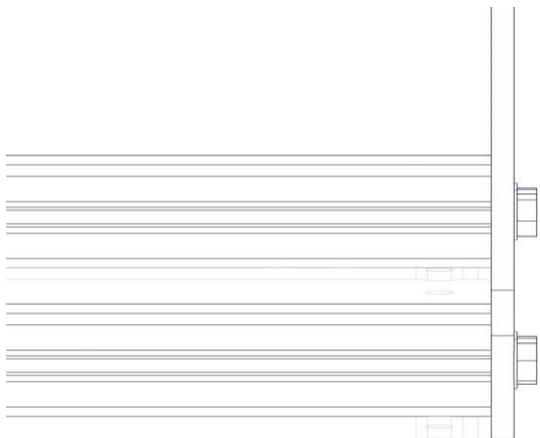

Step 2: Secure the other handle to the opposite side in the same manner.

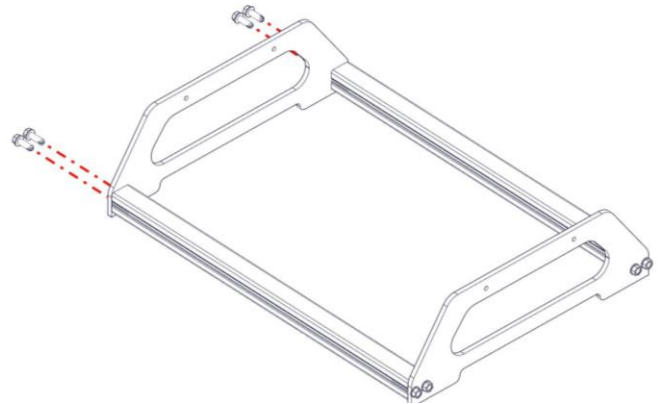

Step 4: Place the Driver Tray Bottom Panel (am-4548_panel) onto the Peanut between the handles.

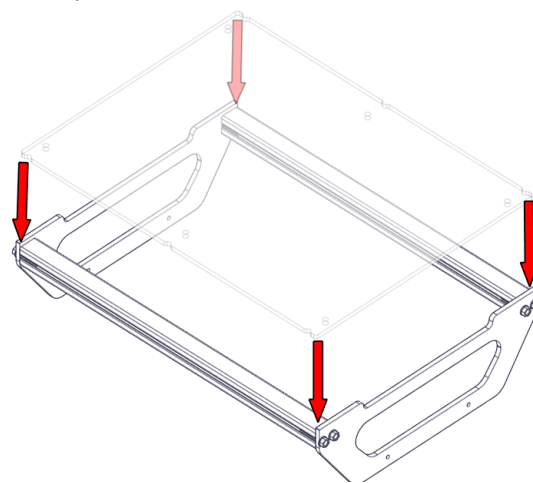

Step 6: Wrap the 6 cable ties (am-1189_1) through the pre-drilled holes in the Driver Tray Bottom Panel and around the Peanut Extrusion. Tighten until fully secure.

